

Douglas N. Bachman, P.E., P.S. Tuscarawas County Engineer

832 Front Avenue SW, New Philadelphia, OH 44663

Phone: (330) 339-6648 Email: engineer@co.tuscarawas.oh.us

APPLICATION FOR DRIVEWAY PERMIT

Date: _____

Permit Fee **\$20.00**

Application is hereby made by _____

of _____
(address) (phone number)

to install a driveway on the N S E W side of County Road _____
(road number and name)

at the following location: _____ miles _____ feet N S E W of

_____ in accordance with the specifications set
(nearest intersection of another public road)

forth by the County Engineer.

Installation of driveway and pipe to be done by _____
(contractor)

on or about _____
(date)

email _____ Signature _____

PERMIT (to be completed by the Engineer's Office)

Type of driveway to be installed:

___ single family private; ___ dedicated private drive (requires approval through Regional Planning); ___ commercial;
change of use; ___ other _____

Pipe to be installed: _____
length size type

Driveway and pipe must be installed as to the specifications set forth and issued by the County Engineer.

Safe Speed Limit _____ mph

Corresponding Required Sight Distance per the **Access Management Regulations** of Tuscarawas County (effective April 1, 2005) _____ ft.

Approx Actual Sight Distance _____ ft. right
_____ ft. left

_____ Date

_____ County Engineer or authorized agent

DRIVEWAY SPECIFICATIONS

Tuscarawas County Engineer
(330) 339-6648

Revised September 23, 2016

1. A driveway permit is required for any new driveway or any existing driveway with a proposed change of use, for a Tuscarawas County Road.
2. Location, type and size of pipe must be approved by a representative of the County Engineer prior to a permit being issued. Pipe installed must be a minimum of 40 feet in length and 12 inches in diameter.
3. Permittee to furnish all labor, material and equipment necessary to complete and maintain the driveway and pipe. All work must be done by a qualified contractor.
4. The Permittee is held responsible for keeping the County Road free and clear of mud and debris in the area of operation.
5. The Permittee assumes all responsibility for cleaning and maintaining of the authorized drainage installation.
6. Existing roadside drainage to remain undisturbed.
7. The portion of excavation on County right-of-way must be seeded to prevent erosion.
8. The Permittee agrees that Tuscarawas County shall be held harmless from any or all claims or damages, public or private, arising from or growing out of the issuance of this permit.
9. No machinery or material to be stored on the roadway at any time.
10. Traffic to be maintained on the County Road at all times.
11. The Permittee must notify the County Engineer's Office at least 24 hours prior to installation of drive. No concrete or asphalt drive approaches shall be constructed without contacting the Engineer's Office to approve grading or formwork **prior** to placing concrete or asphalt
12. Dedicated Private Drives must be submitted through the Regional Planning Office prior to issuance of driveway permit.
13. Commercial driveways must be approved by plan being submitted to the County Engineer by the developer.
14. The County Engineer's Office will notify property owners of any installations which do not meet these specifications, and allow the property owner two (2) weeks to correct the driveway. Should no corrective action be taken, the county reserves the right to perform corrective work and invoice the property owner for all labor and materials necessary.

PRIVATE DRIVE - TYPICAL PLAN VIEW

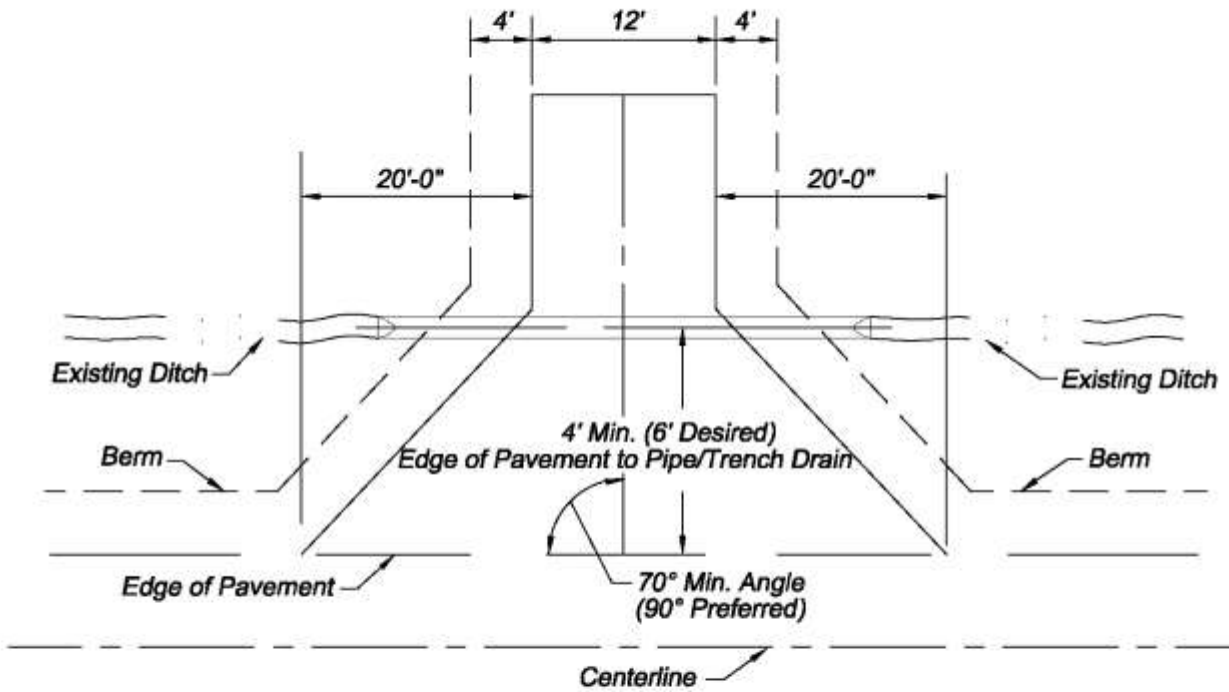

PRIVATE DRIVE - TYPICAL PROFILE

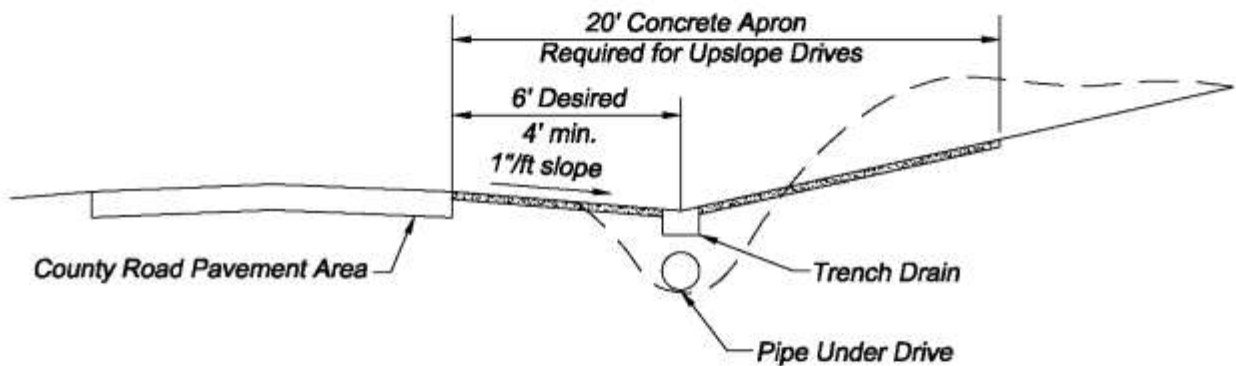

1. All driveways must slope down from the edge of pavement at least 1" per foot to ditch line before slope is started up grade. In no case shall the driveway or berm elevation be above the edge of pavement elevation within six (6) feet of the edge of pavement.
2. Any driveway sloping upward from the roadway must be constructed with a concrete apron extending at least 20 feet from the edge of pavement. A trench drain, with a 6" minimum grate size extending the full width of the driveway, shall be installed integral with the concrete apron. The trench drain shall outlet into the drive pipe or ditch line beyond the drive pipe.
3. The County reserves the right to require any and all such measures, including uphill ditching, water diversion, or additional drainage structures as required to keep water, ice, mud, and aggregate from running onto or accumulating on the roadway surface.

TUSCARAWAS COUNTY ROAD & BRIDGE DEPARTMENT
Mailbox Location & Specifications

The following are the United States Postal Service mailbox regulations:

Posts and other supports for curbside boxes are owned and controlled by customers, who are responsible for seeing that posts are neat and of adequate strength and size. Customers are encouraged to avoid using massive mailbox supports that, when struck, could damage vehicles and cause injury. Heavy metal posts, concrete posts and miscellaneous farm equipment, such as milk cans filled with concrete, are examples of potentially dangerous supports. The ideal support is an assembly that bends or falls away when struck by a vehicle.

The Federal Highway Administration (FHWA) has determined that mailbox supports no larger than 4 inches by 4 inches, or a 2-inch diameter standard steel or aluminum pipe, should safely break away if struck by a vehicle. The box must also be securely attached to its post to prevent separation if struck.

Generally, customers should install boxes with the bottom of the box at a vertical height of between 3 to 4 feet from the road surface. However, because of varying road and curb conditions and other factors, the Postal Service recommends that customers contact the postmaster or carrier before erecting or replacing mailboxes and supports.

In addition, the Tuscarawas County Road and Bridge Department has the following regulations:

- 1) The mailbox should be located to give adequate sight distance to the mail carrier; i.e. avoid placing mailbox on a blind curve or near a blind hill crest.
- 2) Construction and maintenance of the mail carrier's pull-off area is the responsibility of the homeowner. The County should be consulted prior to the construction of any pull-off area having other than an aggregate surface.
- 3) Mailboxes should be located a minimum of four (4) feet from the front of the mailbox to the edge of pavement and secure enough to withstand the effect of heavy snow and slush thrown from snow plows. The County will repair/replace **only** those mailboxes physically hit by County Equipment as a result of our equipment leaving the roadway.
- 4) The house number should be posted so that it is clearly visible in both directions so that the number can be seen by an emergency vehicle approaching in either direction. Reflective letters at least 3 inches in height are recommended.